

Proper AC Motor Lubrication

Document number B-5021
From December, 1987
Issue of Engineer's Digest

Open Bearing | Sealed Bearing | Shielded Bearing | | Lubrication Techniques | Over greasing |

The service life of most motors is dependent on a little bit of good grease at the right times. This report discusses the pros and cons of different types of bearings, under- or-over-lubrication problems, and proper lubrication techniques.

Most motor failures are related to bearing failures. However, most bearing failures are not the result of bearing fatigue but improper lubrication. Bearing fatigue life calculations are commonly referred to as L-10 life (previously B-10). These calculations, expressed in thousands of hours of bearing life, give a good indication if a specific bearing can handle a specific load; but they can not and *should not* be used to predict bearing life. Why? Because it all comes back to taking care of that bearing with good lubrication practice.

Before we can discuss good lubrication practices we need to understand the basic types of bearings that motor manufacturers generally use, along with their advantages and disadvantages.

Open Bearing

Single Row, Deep Groove Ball Bearing: This is sometimes called a Conrad bearing and is listed by AFBMA (Anti-Friction Bearing Manufacturers Association) as Type BC (single row radial contact without filling slot).

The Conrad open bearing is assembled by eccentrically offsetting the thinner and outer races to allow the insertion of balls (see figure below). The Conrad type bearing therefore has uninterrupted raceways (no filling slot) which permits excellent bearing performance under light to moderate radial loads, relatively moderate thrust loads, or combined radial and thrust loads. This bearing is also somewhat self-aligning and typically allows for a minor misalignment of $^{\circ}f$ without affecting the bearing operation and life.

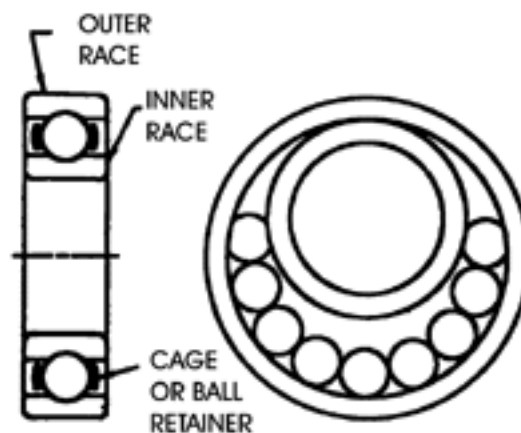

Open Bearing

Advantages:

- 1. Open bearings (non-shielded) minimize friction allowing cooler bearing operation.
- 2. Not as susceptible to overgreasing because they have no shields to collapse.
- 3. Allows for complete and unrestricted grease relubrication.

Disadvantages:

- 1. The bearing system must be designed to protect the open bearing from contamination.
- 2. Grease must be restricted from migrating out of the bearing cavity.

Sealed Bearing

A "sealed" cartridge width bearing is a variation of the standard deep groove Conrad bearing. The construction of the raceway, cage, and ball assembly is the same; however, between the inner and outer rings are mechanical non-metallic seals. A "sealed" bearing cannot be relubricated.

Advantages:

- 1. Entry of contamination is greatly restricted.
- 2. No regular relubrication is necessary.

Disadvantages:

- 1. The bearing life is limited by the amount of lubrication packed between the seals of the bearing and the lubricant life.
- 2. The practicality of using sealed bearings is restricted due to the excessive heating on larger sizes.
- 3. Maintenance requires replacement of the bearing.

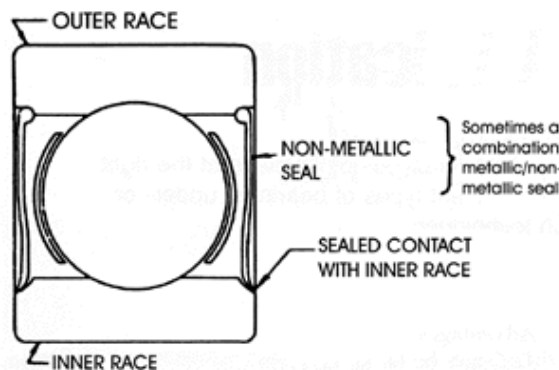

Sealed Bearing

Shielded Bearing

A shielded bearing also is a variation of the Conrad bearing and is similar to the sealed-type bearing except that the shielded bearing has a metallic rather than a non-metallic shield. The metal member is secured to the outer race with a close running clearance to the inner race. With care, a shielded bearing can be relubricated. (A shielded bearing may be shielded on one side or both sides.)

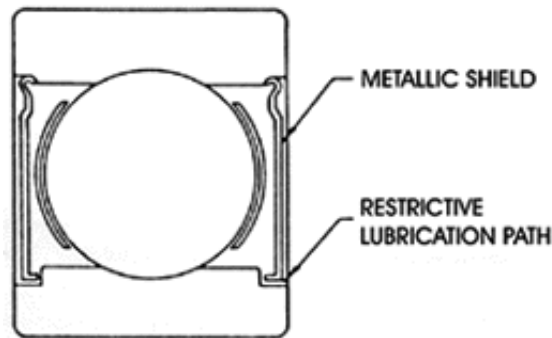

Shielded Bearing

Advantages:

1. Retains the lubricant at the rolling elements regardless of the chamber fill.
2. Provides relubrication to the balls by the slinger feeding of inner race.
3. Restricts contamination from getting into the rolling elements at installation and during operation.

Disadvantage:

1. Excessive pressure with no relief provided can force the shield against the cage or balls, eliminating regreasability or causing immediate failure.

Lubrication Techniques

If most motor failures are due to lubrication problems-how do they fail? First, it could be lack of lubrication for whatever reason. Second, it could be contamination of the bearing system. Third, believe it or not-too much grease.

We all know that if you don't grease a motor, sooner or later it's going to fail. Or if for some reason (such as heavy washdown usage) you lose grease in the bearing, a failure is imminent. High motor and bearing temperatures also will tend to dry up the grease over time.

Contamination due to dirt and other foreign matter also should cause concern. Dirt and other hard particles such as metal and chips from abrasive wheels can get into the bearing raceways and be squeezed between the balls and raceway. This will cause roughness of the race and ball and will eventually cause failure. If the particles are a consistency of a very fine dust, they will act like a lapping compound and cause accelerated wear of the races and ball.

So like it or not, we are faced with regreasing most motors. It is important, when we do regrease, that the grease is clean and fresh; that the grease entry is also free of dirt and contamination; and most important, that the new grease is compatible with the existing grease.

Overgreasing

In many cases overgreasing can be just as damaging as undergreasing. Heat is the biggest enemy a bearing has, and overgreasing causes the bearings to run at higher temperatures. When you combine overgreasing with other factors such as high bearing loading, you get excessive bearing heating and premature failure.

The other concern of overgreasing is that if the bearing is the shielded type, excessive pressure with no relief provided can force the shield against the cage or balls, thereby, eliminating regreasability or causing an immediate failure.

How much is enough?

An easy question without an easy answer. The best advice is to consult the manufacturers instruction manual. Remember this rule of thumb: **It is better to use a little grease more often than a lot of grease less often.** Re-lubrication frequency depends on environmental conditions. Under extreme conditions such as heavy shock, vibration, or dust, relubrication every one to three months is not uncommon. Under normal conditions relubrication every year or longer may be acceptable. Here again the manufacturer’s recommendation and experience are the best guidelines. But nobody, including the motor manufacturer, knows the application and lubrication needs better than the people that work with the equipment every day.

Another tip is to regrease the motor while it’s still warm. This will allow the existing dirty grease to flow freely and it will provide better relubrication. Also, remember to unplug grease drains (if provided) during regreasing(See Photos). For safety reason always disconnect power before relubricating.

A little bit of common sense, a little bit of grease, and a good lubrication schedule will keep the industrial motors of today running a long, long time.



(Unplug)



(Relubrication)



(Old grease out)



(Pulsarlube M)